



## OMEGA BINOCULAR

## 10X42RF

ATN is proud to introduce its professional brand of daytime binoculars: the **Omega line**. Years of manufacturing German quality glass for our Night Vision equipment have allowed us to produce a binocular line with exceptional quality at a reasonable price.

The **Omega binoculars** are technologically advanced with special coated optics, nitrogen filled, durable rubber armor, and either a built-in range finder or a built-in compass. These binoculars are tough, provide a crystal clear image, and are of the highest quality.

Each model is durable enough to withstand the harshest conditions and is designed to perform under the most stressful situations. This is guaranteed by the lifetime manufacturer's defect warranty on all of the models in the Omega line.

ATN's **10x42RF** daytime Omega class binoculars are the quintessential professional binoculars. They provide a sharp stable image with excellent low-light performance.

Features multi-coated optics for superior light transmission, individual diopter focus for clearer images, built-in range finder reticle and full rubber armoring for increased shock resistance.

The combination of waterproof and high quality optics make it the perfect binocular for military, law enforcement, boating as well as for most hunting uses.

Meets standards and requirements of MIL-STD810 for a lifetime of high performance.

- Meets standards and requirements of MIL-STD810
- Built for professional use
- Multi-Coated Optics
- Built-in Rangefinder
- Full rubber armoring
- Waterproof & shockproof
- O-ring sealed & Nitrogen purged
- Limited Lifetime Warranty

### SPECIFICATIONS

MAGNIFICATION	10X
FOV	105 m @ 1000 m
DIOPTER ADJUSTMENT	-5 / +7
OPERATING TEMPERATURE	-43°C to +55°C
LENGHT	155 mm / 6.1"
WEIGHT	0.76 kg / 1.68 lbs

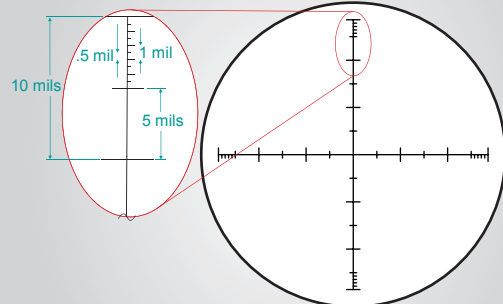

Export Warning: These products are subject to one or more of the export control laws and regulations of the U.S. Government. Pending the model these products are under the control jurisdiction of either the US Department of State or the US Bureau of Industry and Security US Department of Commerce. Export without proper licensing or consent is strictly prohibited.

1341 San Mateo Ave,  
South San Francisco, CA 94080.

[www.atncorp.com](http://www.atncorp.com)  
e-mail: [sales@atncorp.com](mailto:sales@atncorp.com), [info@atncorp.com](mailto:info@atncorp.com)

Tel: 800-910-2862, 650-989-5100,  
fax: 650-875-0129